

An optimal control problem on the special Euclidean group $SE(3, \mathbb{R})$

Mircea Craioveanu, Camelia Pop, Anania Aron, Camelia Petrişor

*Dedicated to the 70-th anniversary
of Professor Constantin Udriste*

Abstract. Let $SE(3, \mathbb{R})$ be the special Euclidean group. A controllable drift-free system on $SE(3, \mathbb{R})$ is considered. The dynamics and geometrical properties of the corresponding reduced Hamilton's equations on $(se(3, \mathbb{R})^*, \{\cdot, \cdot\}_-)$ are studied, where $\{\cdot, \cdot\}_-$ is the minus Lie-Poisson structure on the dual space $se(3, \mathbb{R})^*$ of the Lie algebra $se(3, \mathbb{R})$ of $SE(3, \mathbb{R})$. The numerical integration of this system is also discussed.

M.S.C. 2000: 53D17.

Key words: Optimal control problem; nonlinear stability; numerical integration; Kahan integrator; Lie-Trotter integrator.

1 Introduction

In the last time there was a great deal of interest in the study of control problems on matrix Lie groups due to their applications in spacecraft dynamics [16], [17], subatomic dynamics [5] or aquatic systems [4]. The goal of our paper is to study an optimal control problem on a particular Lie group and to point out some of its dynamical and geometrical properties. Similar problems have been studied on the Lie group $SO(4)$ (see [6]) and on $SE(2, \mathbb{R}) \times SO(2)$ (see [7]).

We consider a controllable drift-free system on the Lie group $SE(3, \mathbb{R})$. The dynamics and geometrical properties of the corresponding reduced Hamilton's equations on $(se(3, \mathbb{R})^*, \{\cdot, \cdot\}_-)$ are studied, where $\{\cdot, \cdot\}_-$ is the minus Lie-Poisson structure on the dual space $se(3, \mathbb{R})^*$ of the Lie algebra $se(3, \mathbb{R})$ of $SE(3, \mathbb{R})$. In particular, by using the energy-Casimir method, the Lyapunov stability of equilibria of this system is studied. In the last section of the paper we consider three numerical integrators associated to the system and we point out some of their properties.

2 The geometrical picture of the problem

Let $SE(3, \mathbb{R})$ be the 6-dimensional Lie group given by

$$SE(3, \mathbb{R}) = \left\{ \begin{bmatrix} A & v \\ 0 & 1 \end{bmatrix}, A \in SO(3), v \in \mathbb{R}^3 \right\}.$$

Its Lie algebra is given by:

$$se(3, \mathbb{R}) = \left\{ \begin{bmatrix} 0 & -a & b & x \\ a & 0 & -c & y \\ -b & c & 0 & z \\ 0 & 0 & 0 & 0 \end{bmatrix}, a, b, c, x, y, z \in \mathbb{R} \right\} \cong \mathbb{R}^6.$$

A basis of the Lie algebra is given by the next matrices:

$$A_1 = \begin{bmatrix} 0 & 0 & 0 & 0 \\ 0 & 0 & -1 & 0 \\ 0 & 1 & 0 & 0 \\ 0 & 0 & 0 & 0 \end{bmatrix}, A_2 = \begin{bmatrix} 0 & 0 & 1 & 0 \\ 0 & 0 & 0 & 0 \\ -1 & 0 & 0 & 0 \\ 0 & 0 & 0 & 0 \end{bmatrix}, A_3 = \begin{bmatrix} 0 & -1 & 0 & 0 \\ 1 & 0 & 0 & 0 \\ 0 & 0 & 0 & 0 \\ 0 & 0 & 0 & 0 \end{bmatrix},$$

$$A_4 = \begin{bmatrix} 0 & 0 & 0 & 1 \\ 0 & 0 & 0 & 0 \\ 0 & 0 & 0 & 0 \\ 0 & 0 & 0 & 0 \end{bmatrix}, A_5 = \begin{bmatrix} 0 & 0 & 0 & 0 \\ 0 & 0 & 0 & 1 \\ 0 & 0 & 0 & 0 \\ 0 & 0 & 0 & 0 \end{bmatrix}, A_6 = \begin{bmatrix} 0 & 0 & 0 & 0 \\ 0 & 0 & 0 & 0 \\ 0 & 0 & 0 & 1 \\ 0 & 0 & 0 & 0 \end{bmatrix}.$$

The Lie algebra structure of $se(3, \mathbb{R})$ is given by the following table:

[.,.]	A_1	A_2	A_3	A_4	A_5	A_6
A_1	0	A_3	$-A_2$	0	A_6	$-A_5$
A_2	$-A_3$	0	A_1	$-A_6$	0	A_4
A_3	A_2	$-A_1$	0	A_5	$-A_4$	0
A_4	0	A_6	$-A_5$	0	0	0
A_5	$-A_6$	0	A_4	0	0	0
A_6	A_5	$-A_4$	0	0	0	0

Now, a general left invariant drift free control system on $SE(3, \mathbb{R})$ with fewer controls than state variables can be written in the following form:

$$\dot{X} = X \left(\sum_{i=1}^m u_i A_i \right),$$

where $X \in SE(3, \mathbb{R})$, the scalar functions $u_i, i = 1, 2, \dots, m$, are the control inputs, and $m < 6$.

In all what follows we shall concentrate on the following left-invariant, drift-free control system on $SE(3, \mathbb{R})$ with three controls:

$$(2.1) \quad \dot{X} = X (u_1 A_1 + u_3 A_3 + u_4 A_4),$$

Then we have:

Proposition 2.1. *The system (2.1) is controllable.*

Proof. Since the span of the set of Lie brackets generated by A_1, A_3, A_4 coincides with $se(3, \mathbb{R})$, the Proposition is a consequence of a result due to Jurdjevic and Sussman ([13]). \square

3 An optimal control problem associated to the system (2.1)

Let J be the cost function given by:

$$J(u_1, u_3, u_4) := \frac{1}{2} \int_0^{t_f} [c_1 u_1^2(t) + c_3 u_3^2(t) + c_4 u_4^2(t)] dt$$

$$c_1 > 0, c_3 > 0, c_4 > 0.$$

Then we have:

Proposition 3.1. *The controls that minimize J and steer the system (2.1) from $X = X_0$ at $t = 0$ to $X = X_f$ at $t = t_f$ are given by:*

$$u_1 = \frac{1}{c_1} x_1, \quad u_3 = \frac{1}{c_3} x_3, \quad u_4 = \frac{1}{c_4} x_4,$$

where x'_i 's are solutions of the following system of differential equations:

$$(3.1) \quad \left\{ \begin{array}{l} \dot{x}_1 = \frac{1}{c_3} x_2 x_3, \\ \dot{x}_2 = \left(\frac{1}{c_1} - \frac{1}{c_3} \right) x_1 x_3 + \frac{1}{c_4} x_4 x_6, \\ \dot{x}_3 = -\frac{1}{c_1} x_1 x_2 - \frac{1}{c_4} x_4 x_5, \\ \dot{x}_4 = \frac{1}{c_3} x_3 x_5, \\ \dot{x}_5 = \frac{1}{c_1} x_1 x_6 - \frac{1}{c_3} x_3 x_4, \\ \dot{x}_6 = -\frac{1}{c_1} x_1 x_5. \end{array} \right.$$

Proof. Let us apply Krishnaprasad's theorem (see [15]). It follows that the optimal Hamiltonian is given by:

$$H_{opt}(x_1, x_3, x_4) := \frac{1}{2} \left(\frac{x_1^2}{c_1} + \frac{x_3^2}{c_3} + \frac{x_4^2}{c_4} \right).$$

It is in fact the controlled Hamiltonian \bar{H} given by:

$$\bar{H}(x_1, x_3, x_4, u_1, u_3, u_4) = x_1 u_1 + x_3 u_3 + x_4 u_4 - \frac{1}{2} (c_1 u_1^2 + c_3 u_3^2 + c_4 u_4^2),$$

which is reduced to $se(3, \mathbb{R})_-^*$ via Poisson reduction. Here $se(3, \mathbb{R})_-^*$ is the dual $se(3, \mathbb{R})^* \cong \mathbb{R}^6$ of the Lie algebra $se(3, \mathbb{R})$ together with the minus-Lie-Poisson struc-

ture given by the matrix:

$$\Pi_- = \begin{bmatrix} 0 & -x_3 & x_2 & 0 & -x_6 & x_5 \\ x_3 & 0 & -x_1 & x_6 & 0 & -x_4 \\ -x_2 & x_1 & 0 & -x_5 & x_4 & 0 \\ 0 & -x_6 & x_5 & 0 & 0 & 0 \\ x_6 & 0 & -x_4 & 0 & 0 & 0 \\ -x_5 & x_4 & 0 & 0 & 0 & 0 \end{bmatrix}.$$

Then the optimal controls are given by

$$u_1 = \frac{1}{c_1}x_1, \quad u_3 = \frac{1}{c_3}x_3, \quad u_4 = \frac{1}{c_4}x_4,$$

where x_i 's are solutions of the reduced Hamilton's equations on $(se(3, \mathbb{R})^*, \{\cdot, \cdot\}_-)$ given by:

$$[\dot{x}_1, \dot{x}_2, \dot{x}_3, \dot{x}_4, \dot{x}_5, \dot{x}_6]^t = \Pi_- \cdot \nabla H_{opt}$$

which are nothing else than the required equations (3.1). \square

Proposition 3.2. *The dynamics (3.1) has the following Hamilton-Poisson realization:*

$$(\mathbb{R}^6, \Pi_-, H),$$

where

$$\Pi_- := \begin{bmatrix} 0 & -x_3 & x_2 & 0 & -x_6 & x_5 \\ x_3 & 0 & -x_1 & x_6 & 0 & -x_4 \\ -x_2 & x_1 & 0 & -x_5 & x_4 & 0 \\ 0 & -x_6 & x_5 & 0 & 0 & 0 \\ x_6 & 0 & -x_4 & 0 & 0 & 0 \\ -x_5 & x_4 & 0 & 0 & 0 & 0 \end{bmatrix}$$

and

$$H(x_1, x_2, x_3, x_4, x_5, x_6) := \frac{1}{2} \left(\frac{x_1^2}{c_1} + \frac{x_3^2}{c_3} + \frac{x_4^2}{c_4} \right).$$

Proof. Indeed, it is not hard to see that the dynamics (3.1) can be put in the equivalent form:

$$[\dot{x}_1, \dot{x}_2, \dot{x}_3, \dot{x}_4, \dot{x}_5, \dot{x}_6]^t = \Pi_- \cdot \nabla H,$$

as required. \square

Via Bermejo-Feiren's technique [9] we are immediately lead to:

Proposition 3.3. *The smooth real functions C_1 and C_2 given by:*

$$C_1(x_1, x_2, x_3, x_4, x_5, x_6) = \frac{1}{2}(x_4^2 + x_5^2 + x_6^2)$$

$$C_2(x_1, x_2, x_3, x_4, x_5, x_6) = x_1x_4 + x_2x_5 + x_3x_6$$

are Casimirs of our Poisson structure.

The goal of our paper is to study some geometrical and dynamical properties of the system (3.1).

4 Stability

Let us consider now $c_1 = 1$ and $c_3, c_4 > 0$. Using MATHEMATICA, we can see that the equilibrium states of our dynamics (3.1) are:

$$\begin{aligned} e_1^{M,N,P} &:= (0, M, 0, 0, N, P), \quad M, N, P \in \mathbb{R}, \\ e_2^{M,N} &:= (0, 0, M, 0, 0, N), \quad M, N \in \mathbb{R}, \\ e_3^{M,N} &:= (M, 0, 0, N, 0, 0), \quad M, N \in \mathbb{R}, \\ e_4^{M,N} &:= (0, M, 0, N, 0, 0), \quad M, N \in \mathbb{R}. \end{aligned}$$

If $0 < c_3 < 1$, our dynamics has two more equilibrium states:

$$\begin{aligned} e_5^{M,N} &:= \left(M, 0, N, -M\sqrt{c_4(1-c_3)}, 0, -N\frac{\sqrt{c_4(1-c_3)}}{c_3} \right), \quad M, N \in \mathbb{R}, \\ e_6^{M,N} &:= \left(M, 0, N, M\sqrt{c_4(1-c_3)}, 0, N\frac{\sqrt{c_4(1-c_3)}}{c_3} \right), \quad M, N \in \mathbb{R}. \end{aligned}$$

Then we have:

Proposition 4.1. *The equilibrium states $e_1^{M,N,P}$, $M, N, P \in \mathbb{R}$, are spectrally stable for any $M, N, P \in \mathbb{R}^*$.*

Proof. Let A be the matrix of the linear part of our system (3.1). It is easy to see that the eigenvalues of the matrix $A(e_1^{M,N,P})$ are:

$$\lambda_{1,2,3,4} = 0, \quad \lambda_{5,6} = \pm i \sqrt{\frac{N^2 + c_4 M^2}{c_3 c_4}}$$

and then our assertion follows immediately. \square

Proposition 4.2. *The equilibrium states $e_2^{M,N}$, $M, N \in \mathbb{R}^*$, are spectrally stable if*

$$0 < c_3 < 1, \quad N \in \left(-|M| \frac{\sqrt{c_4(1-c_3)}}{c_3}, |M| \frac{\sqrt{c_4(1-c_3)}}{c_3} \right).$$

Proof. We shall use the energy-Casimir method (see [8] and [6]). Let

$$\begin{aligned} F_{\varphi,\psi}(x_1, x_2, x_3, x_4, x_5, x_6) &:= 3D(H + \varphi(C_1) + \psi(C_2))(x_1, x_2, x_3, x_4, x_5, x_6) \\ &= \frac{x_1^2}{2c_1} + \frac{x_3^2}{2c_3} + \frac{x_4^2}{2c_4} + \varphi(x_1 x_4 + x_2 x_5 + x_3 x_6) + \psi\left(\frac{1}{2}(x_4^2 + x_5^2 + x_6^2)\right) \end{aligned}$$

be the energy-Casimir function, where $\varphi, \psi : \mathbb{R} \rightarrow \mathbb{R}$ are smooth real functions. Now, the first variation of $F_{\varphi,\psi}$ at the equilibrium of interest equals zero if and only if

$$\begin{cases} \dot{\varphi}(MN) = 0, \\ \dot{\psi}\left(\frac{N^2 + P^2}{2}\right) = 0. \end{cases}$$

The second variation of $F_{\varphi,\psi}$ at the equilibrium of interest is given by:

$$\begin{aligned} \delta^2 F_{\varphi,\psi} \left(e_1^{M,N,P} \right) &= \frac{1}{c_1} (\delta x_1)^2 + \frac{1}{c_3} (\delta x_3)^2 + \frac{1}{c_4} (\delta x_4)^2 \\ &\quad + \ddot{\varphi}(MN) (N\delta x_2 + P\delta x_3 + M\delta x_5)^2 + \ddot{\psi} \left(\frac{N^2 + P^2}{2} \right) (N\delta x_5 + P\delta x_6). \end{aligned}$$

Choosing φ, ψ such that

$$\begin{cases} \ddot{\varphi}(MN) > 0, \\ \ddot{\psi} \left(\frac{N^2 + P^2}{2} \right) > 0, \end{cases}$$

we can conclude that the second variation of $F_{\varphi,\psi}$ at the equilibrium of interest is positive definite and thus $e_1^{M,N,P}$ is nonlinearly stable. \square

For the equilibrium states $e_3^{M,N}$, $M, N \in \mathbb{R}$, the computations are very complicated and the conditions which are obtained cannot be put in a simple form. Therefore we will not give other details.

Proposition 4.3. *The equilibrium states $e_4^{M,N}$, $M, N \in \mathbb{R}^*$, are spectrally stable if*

$$N \in (-|M| \sqrt{c_4}, |M| \sqrt{c_4}).$$

Proof. It is easy to see that the characteristic polynomial of the matrix $A(e_4^{M,N})$ has the following expression:

$$\frac{\lambda^4}{c_3 c_4} (c_3 c_4 \lambda^2 - N^2 + M^2 c_4)$$

and our assertion follows immediately. \square

The equilibrium states $e_5^{M,N}$ and $e_6^{M,N}$, $M, N \in \mathbb{R}$, are unstable.

Let us discuss the nonlinear stability of some of these equilibria. We have the following result:

Proposition 4.4. *The equilibrium states $e_1^{M,N,P}$, $M, N, P \in \mathbb{R}$, are nonlinearly stable for any $M, N, P \in \mathbb{R}^*$.*

Proof. We shall use the energy-Casimir method (see [10] and [8]). Let

$$\begin{aligned} F_{\varphi,\psi}(x_1, x_2, x_3, x_4, x_5, x_6) &= (H + \varphi(C_1) + \psi(C_2))(x_1, x_2, x_3, x_4, x_5, x_6) \\ &= \frac{x_1^2}{2c_1} + \frac{x_3^2}{2c_3} + \frac{x_4^2}{2c_4} + \varphi(x_1 x_4 + x_2 x_5 + x_3 x_6) + \psi\left(\frac{1}{2}(x_4^2 + x_5^2 + x_6^2)\right) \end{aligned}$$

be the energy-Casimir function, where $\varphi, \psi : \mathbb{R} \rightarrow \mathbb{R}$ are smooth real functions. Now, the first variation of $F_{\varphi,\psi}$ at the equilibrium of interest equals zero if and only if

$$\begin{cases} \dot{\varphi}(MN) = 0, \\ \dot{\psi} \left(\frac{N^2 + P^2}{2} \right) = 0. \end{cases}$$

The second variation of $F_{\varphi,\psi}$ at the equilibrium of interest is given by:

$$\begin{aligned} \delta^2 F_{\varphi,\psi}(e_1^{M,N,P}) &= \frac{1}{c_1}(\delta x_1)^2 + \frac{1}{c_3}(\delta x_3)^2 + \frac{1}{c_4}(\delta x_4)^2 \\ &+ \ddot{\varphi}(MN)(N\delta x_2 + P\delta x_3 + M\delta x_5)^2 + \ddot{\psi}\left(\frac{N^2 + P^2}{2}\right)(N\delta x_5 + P\delta x_6)^2. \end{aligned}$$

Choosing φ, ψ such that

$$\begin{cases} \ddot{\varphi}(MN) > 0, \\ \ddot{\psi}\left(\frac{N^2 + P^2}{2}\right) > 0, \end{cases}$$

we can conclude that the second variation of $F_{\varphi,\psi}$ at the equilibrium of interest is positive definite and thus $e_1^{M,N,P}$ is nonlinearly stable. \square

Unfortunately, for the rest of equilibrium states the energy-Casimir method does not work. The nonlinear stability problem should be approached with other techniques, and it is still open.

5 Numerical integration of the dynamics (3.1)

It is easy to see that for the equations (3.1), Kahan's integrator (see [14]) can be written in the following form:

$$(5.1) \quad \begin{cases} x_1^{n+1} - x_1^n = \frac{h}{2c_3}(x_3^{n+1}x_2^n + x_2^{n+1}x_3^n), \\ x_2^{n+1} - x_2^n = \frac{h}{2}\left(\frac{1}{c_1} - \frac{1}{c_3}\right)(x_1^{n+1}x_3^n + x_3^{n+1}x_1^n) + \frac{h}{2c_4}(x_4^{n+1}x_6^n + x_6^{n+1}x_4^n), \\ x_3^{n+1} - x_3^n = -\frac{h}{2c_1}(x_1^{n+1}x_2^n + x_2^{n+1}x_1^n) - \frac{h}{2c_4}(x_4^{n+1}x_5^n + x_5^{n+1}x_4^n), \\ x_4^{n+1} - x_4^n = \frac{h}{2c_3}(x_3^{n+1}x_5^n + x_5^{n+1}x_3^n), \\ x_5^{n+1} - x_5^n = \frac{h}{2c_1}(x_1^{n+1}x_6^n + x_6^{n+1}x_1^n) - \frac{h}{2c_3}(x_4^{n+1}x_3^n + x_3^{n+1}x_4^n), \\ x_6^{n+1} - x_6^n = -\frac{h}{2c_1}(x_1^{n+1}x_5^n + x_5^{n+1}x_1^n). \end{cases}$$

A long but straightforward computation or using eventually MATHEMATICA lead us to:

Proposition 5.1. *Kahan's integrator (5.1) has the following properties:*

- (i) *It is not Poisson preserving.*
- (ii) *It does not preserve the Casimirs C_1, C_2 of our Poisson configuration $((se(3, \mathbb{R}))^*, \Pi_-)$.*
- (iii) *It does not preserve the Hamiltonian H of our system (3.1).*

We shall discuss now the numerical integration of the dynamics (3.1) via the Lie-Trotter integrator (see [17]). For the beginning, let us observe that the Hamiltonian vector field X_H splits as follows:

$$X_H = X_{H_1} + X_{H_2} + X_{H_3},$$

where

$$H_1(x_1, x_2, x_3, x_4, x_5, x_6) := \frac{1}{2c_1}x_1^2,$$

$$H_2(x_1, x_2, x_3, x_4, x_5, x_6) := \frac{1}{2c_3}x_3^2,$$

$$H_3(x_1, x_2, x_3, x_4, x_5, x_6) := \frac{1}{2c_4}x_4^2.$$

Their corresponding integral curves are respectively given by:

$$\begin{bmatrix} x_1(t) \\ x_2(t) \\ x_3(t) \\ x_4(t) \\ x_5(t) \\ x_6(t) \end{bmatrix} = A_i \begin{bmatrix} x_1(0) \\ x_2(0) \\ x_3(0) \\ x_4(0) \\ x_5(0) \\ x_6(0) \end{bmatrix}, \quad i = 1, 2, 3,$$

where

$$\left\{ \begin{array}{l} A_1 = \begin{bmatrix} 1 & 0 & 0 & 0 & 0 & 0 \\ 0 & \cos at & \sin at & 0 & 0 & 0 \\ 0 & -\sin at & \cos at & 0 & 0 & 0 \\ 0 & 0 & 0 & 1 & 0 & 0 \\ 1 & 0 & 0 & 0 & \cos at & \sin at \\ 1 & 0 & 0 & 0 & -\sin at & \cos at \end{bmatrix}, \\ a = \frac{x_1(0)}{c_1}, \end{array} \right.$$

$$\left\{ \begin{array}{l} A_2 = \begin{bmatrix} \cos bt & \sin bt & 0 & 0 & 0 & 0 \\ -\sin bt & \cos bt & 0 & 0 & 0 & 0 \\ 0 & 0 & 1 & 0 & 0 & 0 \\ 0 & 0 & 0 & \cos bt & \sin bt & 0 \\ 0 & 0 & 0 & -\sin bt & \cos bt & 0 \\ 0 & 0 & 0 & 0 & 0 & 1 \end{bmatrix}, \\ b = \frac{1}{c_3}x_3(0), \end{array} \right.$$

and

$$\left\{ \begin{array}{l} A_3 = \begin{bmatrix} 1 & 0 & 0 & 0 & 0 & 0 \\ 0 & \cos at & \sin at & 0 & 0 & 0 \\ 0 & -\sin at & \cos at & 0 & 0 & 0 \\ 0 & 0 & 0 & 1 & 0 & 0 \\ 1 & 0 & 0 & 0 & \cos at & \sin at \\ 1 & 0 & 0 & 0 & -\sin at & \cos at \end{bmatrix}, \\ c = \frac{x_4(0)}{c_4}. \end{array} \right.$$

Then the Lie-Trotter integrator is given by:

$$(5.2) \quad \begin{bmatrix} x_1^{n+1} \\ x_2^{n+1} \\ x_3^{n+1} \\ x_4^{n+1} \\ x_5^{n+1} \\ x_6^{n+1} \end{bmatrix} = A_1 A_2 A_3 \begin{bmatrix} x_1^n \\ x_2^n \\ x_3^n \\ x_4^n \\ x_5^n \\ x_6^n \end{bmatrix}$$

i.e.

$$(5.3) \quad \left\{ \begin{array}{l} x_1^{n+1} = x_1^n \cos bt + x_2^n \sin bt + ct x_6^n \sin bt, \\ x_2^{n+1} = x_2^n \cos at \cos bt + ct x_6^n \cos at \cos bt + x_3^n \sin at - \\ \quad ct x_5^n \sin at - x_1^n \cos at \sin bt, \\ x_3^{n+1} = x_3^n \cos at - ct x_5^n \cos at - x_2^n \cos bt \sin at - \\ \quad ct x_6^n \cos bt \sin at + x_1^n \sin at \sin bt, \\ x_4^{n+1} = x_4^n \cos bt + x_5^n \sin bt, \\ x_5^{n+1} = x_5^n \cos at \cos bt + x_6^n \sin at - x_4^n \cos at \sin bt, \\ x_6^{n+1} = x_6^n \cos at - x_5^n \cos bt \sin at + x_4^n \sin at \sin bt. \end{array} \right.$$

Now, a direct computation or using eventually MATHEMATICA leads us to:

Proposition 5.2. *The Lie-Trotter integrator (5.3) has the following properties:*

- (i) *It preserves the Poisson structure Π_- .*
- (ii) *It preserves the Casimirs C_1, C_2 of our Poisson configuration $(se(3, \mathbb{R})^*, \Pi_-)$.*
- (iii) *It doesn't preserve the Hamiltonian H of our system (3.1).*
- (iv) *Its restriction to the coadjoint orbit $(\mathcal{O}_k, \omega_k)$, where*

$$\mathcal{O}_k := \left\{ (x_1, x_2, x_3, x_4, x_5, x_6) \in \mathbb{R}^6 \mid \frac{1}{2} (x_4^2 + x_5^2 + x_6^2) = \text{constant}, \right. \\ \left. x_1 x_4 + x_2 x_5 + x_3 x_6 = \text{constant} \right\}$$

and ω_k is the Kirilov-Kostant-Souriau symplectic structure on \mathcal{O}_k , gives rise to a symplectic integrator.

If we make a comparison with the 4th-step Runge-Kutta method, we can see that the Lie-Trotter integrator gives us a good approximation of our dynamics. Unfortunately, Kahan's integrator has failed for this example. It is an open problem who is responsible for this. However, Kahan's integrator and the Lie-Trotter integrator have the advantage to be easier to implement, see Figures 6.1, 6.2 and 6.3.

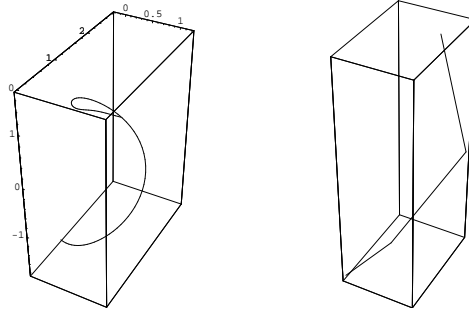

Projection on $Ox_1x_2x_3$. Fig. 6.1: 4th-step Runge-Kutta; Fig. 6.2: Kahan.

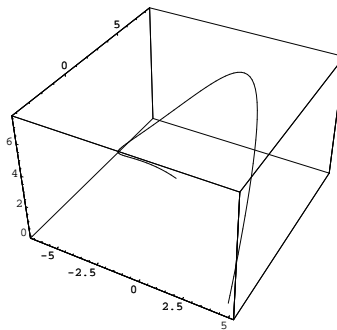

Fig. 6.3: Projection on $Ox_1x_2x_3$: Lie-Trotter integrator.

6 Conclusion

The paper presents a controllable drift-free system on the special Euclidean group $SE(3, \mathbb{R})$; this arises naturally from the study of the underwater vehicle's dynamics for which the Lie group $SE(3, \mathbb{R})$ represents the phase space (see [5]). Moreover, we have discussed the nonlinear stability of some of the equilibrium states and a comparison between three numerical integration methods. We have seen that two of them give us a weak approximation of the movement trajectory, unlike some other examples for which all these three methods provide the same results (for instance in the case of a control system on $SL(2, \mathbb{R})$ or in the case of the 3-dimensional Toda lattice).

References

- [1] A. Aron, C. Pop, *Quadratic and homogeneous Hamilton-Poisson systems on the 13th Lie algebra from Bianchi's classification*, BSG Proc. 17, Geometry Balkan Press 2010, 12-20.

- [2] A. Aron, M. Craioveanu, C. Pop, M. Puta, *Quadratic and homogeneous Hamilton-Poisson systems on $A_{3,6,-1}^*$* , Balkan J. Geom. Appl. 15, 1 (2010), 1-7.
- [3] A.A. Agrachev, Y.L. Sachkov, *Control theory from the geometric viewpoint*, Encyclopedia of Mathematical Sciences, 87. Control Theory and Optimization , II. Springer-Verlag, Berlin, 2004.
- [4] F.B. Agosto, O.M. Bamigbola, *Existence and uniqueness for optimal control of Oxygen absorption in aquatic system*, Appl. Sci. 10 (2008), 9-18.
- [5] A. Aron, P. Birtea, L. Dobre, M. Puta and R. Tudoran, *Some remarks on the underwater vehicle dynamics with a fixed control authority*, In: (Eds.: D.Andrica, P.A.Blaa and S.Moroianu) "Modern Trends in Geometry and Topology", Deva, September 5-11, 2005, 55-62, Cluj University Press, 2006.
- [6] A. Aron, I. Mos, A. Csaky, M. Puta, *An optimal control problem on the Lie group $SO(4)$* , Intern. Journal of Geom. Methods in Modern Physics 5, (2008), 319-327.
- [7] A. Aron, C. Pop, M. Puta, *An optimal control problem on the Lie group $SE(2, \mathbb{R}) \times SO(2)$* , Boletín de la Sociedad Matemática Mexicana (to appear).
- [8] V. Arnold, *Conditions for nonlinear stability of stationary plane curvilinear flows of an ideal fluid*, Doklady 162, 5 (1965), 773-777.
- [9] B.H. Bermejo and V. Fairen, *Simple evaluation of Casimir invariants in infinite dimensional Poisson systems*, Phys. Lett. A 241 (1998), 148-154.
- [10] P.Birtea and M.Pută, *Equivalence of energy methods in stability theory*, Journ. of Math. Physics 48, 4 (2007), 81-99.
- [11] M. Hirsch, S. Smale, R. Devaney, *Differential Equations, Dynamical Systems and an Introduction to Chaos*, Elsevier, Academic Press, New York, 2003.
- [12] V. Jurdjevic, *Optimal control, geometry and mechanics*, Chapter 7 in: (Eds.: J. Baillieul, J.C. Willems) "Mathematical Control Theory", Springer-Verlag, New York Inc., 1999, 227-267.
- [13] V. Jurdjevic and H. J. Sussmann, *Control systems on Lie groups*, Journal of Differential Equations 12 (1972), 313-329.
- [14] W. Kahan, *Unconventional numerical methods for trajectory calculation*, Unpublished Lecture Notes, 1993.
- [15] P.S. Krishnaprasad, *Optimal control and Poisson reduction*, Technical Report 93-87, Institute for System Research, University of Maryland, 1993.
- [16] R. Murray, S.S. Sastry, *Nonholonomic motion planning. Steering using sinusoids*, IEEE Trans. Automat. Control 38 (1998), 700-716.
- [17] M. Puta, *Lie-Trotter formula and Poisson dynamics*, Int. Journ. of Bif. and Chaos 9, 3 (1999), 555-559.

Authors' addresses:

Mircea Craioveanu
 Department of Mathematics, West University of Timișoara,
 4 V. Parvan Blvd., 300223, Timișoara, Romania.

Camelia Pop, Anania Aron, Camelia Petrișor
 Mathematics Department, "Politehnica" University of Timișoara,
 Piața Victoriei no. 2, 300006-Timișoara, Romania.
 E-mail: cariesanu@yahoo.com, ananiagirban@yahoo.com